



Main Features

- Pressure range from 25 mbar to 400 bar
- Flush diaphragm
- Temperature -60 °C ... 400 °C
- Optimized for assembly with transmitters
- Class 150 to 2500
- NPS 2" to 4"
- PN10 to PN100
- DN50 to DN100

Applications

- Oil & Gas / Chemical
- Water / Waste water
- Energy
- Process technic

Technical Data

This diaphragm seals with flanged process connection and flush diaphragm are used to protect pressure transmitters from high temperatures, aggressive or corrosive fluids.

The flush diaphragm allows direct mounting on standardized flange connections of pipes or tanks. With the flush diaphragm these seals are used especially for fluids with high viscosity or a tendency to crystallize.

Different diaphragm materials can be selected to adapt the seal to various applications and process fluids. The wetted part are made of exotic material welded on a stainless steel flange. The flange finish is then equivalent to smooth finish. The diaphragm covers the total surface of the flange face.

The diaphragm seals D92x have been developed especially for the measurement of low pressure ranges in applications with high over-pressure resistance or high static pressure. They are designed for assembly with electronic transmitters for pressure or differential pressure, which can also be used for level or flow measurement. The D92x series cannot be used with pressure gauges. For pressure gauges the series D82x has to be used.

The filling fluid of the measuring system has to be chosen compatible to the application.

Min.pressure ranges	See table on page 2
Temperature	-60 °C ... +400 °C
Filling liquids	LRS4: -20 ... 60 °C (for oxygen) LRS8: 0 ... 300 °C (for vacuum and absolute pressure) LRS9: -40 ... 400 °C (high temperature oil) Other liquids on request
Mounting	Direct or remote from 1.5 to 12 meters
Flange material	Stainless steel 1.4404 (AISI 316L)
Flange types	ASME B16.5 / EN1759-1: class 150 to 2500, NPS 2" to 4". EN1092-1: PN 10 to 100, DN 50 to 100. Available flange faces see table on page 3. Other flange types on request.
Flange face finish	Smooth finish Ra < 0.4
Diaphragm	Hastelloy B2, Hastelloy C276, Hastelloy C4, Tantalum. (covers the total flange face)
Maximum pressure	According to the PN or the class of the flange and its standardized pressure temperature relation

Materials

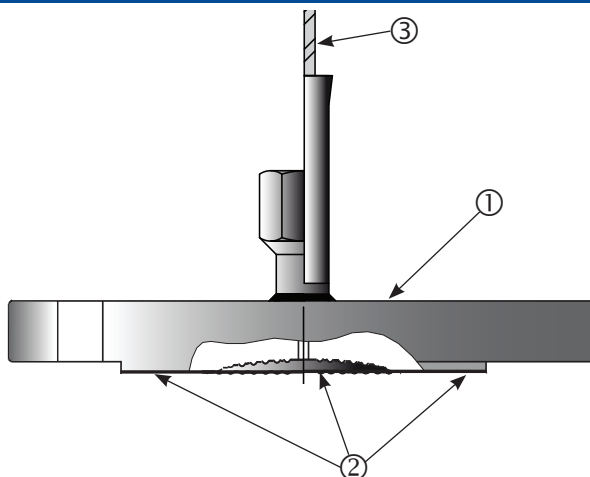

	N°	D924
Flange	①	• Stainless steel 1.4404
Diaphragm	②	• Hastelloy B2 (2.4617) • Hastelloy C276 (2.4819) • Hastelloy C4 (2.4610) • Tantalum
Capillary (option)	③	• Stainless steel

Dimensions (mm)

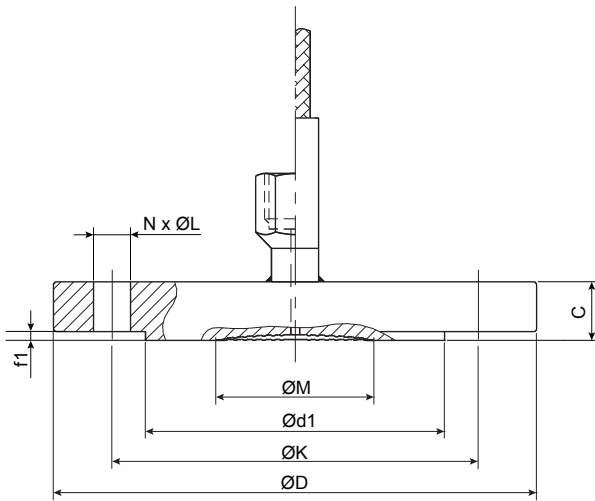

Minimum pressure ranges depending on the active diaphragm diameter Ø M

Ø M ⁽¹⁾ (mm)	Transmitters	
	Gauge and differential	Absolute
54	0 ... 400 mbar	n/a
89	0 ... 25 mbar ⁽²⁾	0 ... 50 mbar
95	0 ... 25 mbar ⁽²⁾	0 ... 50 mbar

⁽¹⁾ Ø M according to dimension tables below.

⁽²⁾ 10 mbar with specific diaphragm (see codification page 4).

Flange dimensions (mm) ANSI B16-5 / EN 1759-1

DN	Class	Ø D	Ø K	Ø L	N	EN1759-1		ANSI B16-5		Ø d1 ⁽¹⁾	Ø M in mm ⁽²⁾	Weight in kg
						C ⁽¹⁾	f1 ⁽¹⁾	C ⁽¹⁾	f1 ⁽¹⁾			
2" (DN50)	150	152	120.6	19	4	19	1.6	19.5	2	91.9	54	2.4
	300	165	127	19	8	22.2	1.6	22.7	2	91.9	54	3.2
	600	165	127	19	8	31.8	6.4	32.4	7	91.9	54	4.2
	900/1500	216	165.1	25.4	8	44.5	6.4	45.1	7	91.9	54	10.1
	2500	235	171.5	28.5	8	57.2	6.4	57.9	7	91.9	54	15.6
3" (DN80)	150	190	152.4	19	4	23.8	1.6	24.3	2	127	89	5
	300	210	168.3	22.2	8	28.6	1.6	29	2	127	89	6.9
	600	210	168.3	22.2	8	38.2	6.4	38.8	7	127	89	8.5
	900	241	190.5	25.4	8	44.5	6.4	45.1	7	127	89	13.1
	1500	267	203.2	31.8	8	54	6.4	54.7	7	127	89	19.2
4" (DN100)	150	229	190.5	19	8	23.8	1.6	24.3	2	157.2	95	7.1
	300	254	200	22.2	8	31.8	1.6	32.2	2	157.2	95	11.6
	600	273	215.9	25.4	8	44.5	6.4	45.1	7	157.2	95	17.3
	900	292	235	31.8	8	50.8	6.4	51.5	7	157.2	95	22.1

Flange dimensions (mm) EN 1092-1

DN	PN	Ø D	C ⁽¹⁾	Ø K	Ø L	N	f1 ⁽¹⁾	Ø d1 ⁽¹⁾	Ø M in mm ⁽²⁾	Weight in kg
50	10/16	165	20	125	18	4	3	102	54	2.9
	25/40	180	26	135	22	4	3	102	54	3.2
	63	195	28	145	26	4	3	102	54	4.6
	100	195	30	145	26	4	3	102	54	5.7
80	10/16	200	20	160	18	8	3	138	89	4.6
	25/40	200	24	160	18	8	3	138	89	5.6
	63	215	28	170	22	8	3	138	89	6.9
	100	230	32	180	26	8	3	138	89	8.9
100	10/16	220	20	180	18	8	3	158	95	5.7
	25/40	235	24	190	22	8	3	162	95	7.6
	63	250	30	200	26	8	3	162	95	10
	100	265	36	210	30	8	3	162	95	13.3



⁽¹⁾ For raised faces, codes B, G, R.

⁽²⁾ Active diameter.

Heatable capillary (option)

- Capillary with low-temperature controlled electric heat tracing
- Reduce influence of environmental temperature
- Improve response time for long capillary
- Decrease in effects of outside temperature:
 - at -40 °C capillary tube temperature over +30 °C
 - at +40 °C capillary tube temperature below +60 °C
- Approx. Ø 25 mm heat insulation
- Sealed outer sheath

Ordering codes for flange faces

Face Type	Drawing	ANSI B16-5		EN 1759-1		EN 1092-1	
			Codes		Codes		Codes
Flat face		Flat face Ra ≤ 0.4 µm	A	Type A Ra ≤ 0.4 µm	A	Type A Ra ≤ 0.4 µm	A
Raised face		Raised face (2) ⁽¹⁾ Raised face (7) ⁽²⁾ Ra ≤ 0.4 µm	G R	Type B (1.6) ⁽¹⁾ Type B (6.4) ⁽²⁾ Ra ≤ 0.4 µm	G R	Type B1 Ra ≤ 0.4 µm	B
Male Spigot		Male spigot large Ra ≤ 0.4 µm	M	Type E Ra ≤ 0.4 µm	M	N/A	N/A

⁽¹⁾ Class 150 and 300

⁽²⁾ Class 600, 900, 1500, 2500

Ordering details D924

D924	-	.	2
Model									
Flanged diaphragm seal with flush diaphragm D924									
Capillary type									
Direct mounting (without)	1								
St. steel tube and protection	A								
St. steel tube and protection and white plastic ATEX sheath	D								
St. steel tube and reinforced protection	F								
St. steel tube and protection, heat-insulated	M								
St. steel tube and protection, traced/heat-insulated	P								
Capillary length									
Without (direct mounting)	0								
1.5 m	E								
3 m	3								
4.5 m	F								
6 m	6								
9 m	9								
12 m	D								
Instrument connection ⁽¹⁾									
G1/2 male	3								
1/2 NPT male	6								
G1/4 male	2								
1/4 NPT male	5								
G1/2 female	L								
1/2 NPT female	N								
For ABB 265 DR (D)	H								
For ABB 265 GR - 265 VS (G)	J								
For Honeywell STD 820/830/720/730 (D)	A								
For Honeywell STG 740/770 (G)	D								
For Honeywell STG 84x/87x/88x (G)	E								
For Honeywell STA 840/740 (A)	G								
For SIEMENS SITRANS Differential (D)	7								
For SIEMENS SITRANS Gauge (G)	8								
For YOKOGAWA EJX110 (low volumes) capsules M, H, V (D)	F								
For YOKOGAWA EJX 430 (low volumes) (G)	V								
For YOKOGAWA EJX 110 (standard flanges) capsules M, H, V (D)	P								
For YOKOGAWA EJX 310/430 (standard flanges) (A) (G)	Q								
For YOKOGAWA EJX 440 (standard flanges) (G)	W								
Flange standard									
ANSI B16-5	2								
EN 1092-1	4								
EN 1759-1	6								
Flange material									
St. steel 316L (1.4404)	2								
PN / Class									
ANSI B16-5 / EN 1759-1									
Class 150	1								
Class 300	2								
Class 600	3								
Class 900	4								
Class 1500	5								
Class 2500	6								
EN 1092-1									
PN10	C								
PN16	D								
PN25	F								
PN40	G								
PN63	N								
PN100	J								
Filling fluid									
00	No filling								
04	LRS4 (for Oxygen) ⁽³⁾								
08	LRS8 (vacuum oil)								
09	LRS9 (high temperature oil)								
Diaphragm coating ⁽²⁾									
0	Without								
1	PTFE 0.02 mm								
4	HALAR 0.2 mm								
7	Gold 15 µm								
Diaphragm material									
5	Hastelloy B2 (2.4617)								
6	Hastelloy C276 (2.4819)								
A	Hastelloy C4 (2.4610)								
D	Hastelloy C276 (2.4819) (P < 25 mbar) ⁽⁴⁾								
7	Tantalum								
Flange face type									
x	See table page 3 (codes)								
DN									
ANSI B16-5 / EN 1759-1									
7	2" (DN50)								
9	3" (DN80)								
V	4" (DN100)								
EN 1092-1									
H	50								
K	80								
L	100								

⁽¹⁾ Type of transmitter: D=Differential / G=Gauge / A=Absolute

⁽²⁾ No coating on Tantalum diaphragms

⁽³⁾ Compulsory with option code 0765 (oxygen degreasing)

⁽⁴⁾ Only DN80 / 3" and DN100 / 4"