

### Main Features

- Pressure range from 160 mbar to 400 bar
- Wetted parts in specific materials
- Temperature -40 °C ... 400 °C
- Class 150 to 2500
- NPS 2" to 3"
- PN10 to PN100
- DN50 to DN80

### Applications

- Oil & Gas / Chemical
- Water / Waste water
- Energy
- Process technic



### Technical Data

This diaphragm seals with flanged process connection and specific materials are used to protect pressure gauges from high temperatures, aggressive or corrosive fluids.

The diaphragm seals allows direct mounting on standardized flange connections of pipes or tanks. With the flush diaphragm these seals are used especially for fluids with high viscosity or a tendency to crystallize.

A wide range of material allows the user to adapt the diaphragm seal to many different type of application and process fluids.

Both diaphragm and body (wetted parts) are made completely from the specific material and welded together. A stainless steel counter flange, which is not in contact with the medium, is used to fix the diaphragm seal on the installation.

The filling fluid of the measuring system has to be chosen compatible to the application.

Min.pressure ranges	See table on page 2
Temperature	-40 °C ... +400 °C
Filling liquids	LRS1: -15 °C ... +150 °C LRS9: -40 °C ... +400 °C high temperature oil Other liquids on request
Mounting	Direct or remote from 1.5 to 12 meters
Flange types	<b>ASME B16.5 / EN1759-1:</b> class 150 to 2500, NPS 2" to 3". <b>EN1092-1:</b> PN 10 to 100, DN 50 to 80. Available flange faces see table on page 3. Other flange types on request.
Diaphragm and body (wetted parts)	Uranus B6, Hastelloy B2, Hastelloy C276, Hastelloy C4, Monel 400, Titanium
Counter flange	Stainless steel 1.4404 (AISI 316L)
Maximum pressure	According to the PN or the class of the flange and its standardized pressure temperature relation

### Materials

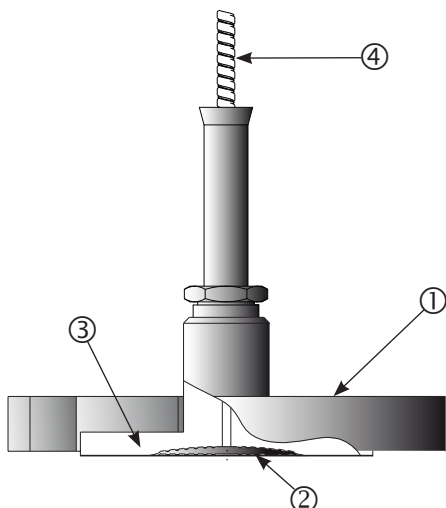

	N°	D825
Counter flange	①	• Stainless steel 1.4404
Diaphragm and Body (wetted parts)	② ③	• Uranus B6 (1.4539) • Hastelloy B2 (2.4617) • Hastelloy C276 (2.4819) • Hastelloy C4 (2.4610) • Monel 400 (2.4360) • Titanium
Capillary (option)	④	• Stainless steel

### Dimensions (mm)

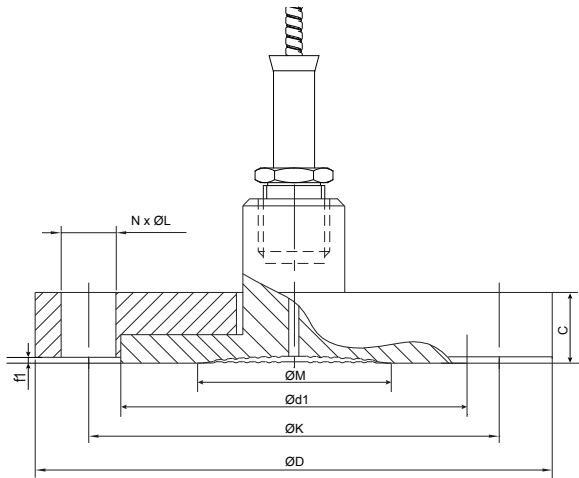

Minimum pressure ranges depending on the active diaphragm diameter  $\varnothing M$  <sup>(1)</sup>

$\varnothing M$ <sup>(2)</sup> (mm)	DN63		DN100/150/160	
	Gauge	Compound	Gauge	Compound
54	0 ... 1 bar	-1 ... 3 bar	0 ... 1 bar	-1 ... 3 bar
89	0 ... 1 bar	-1 ... 0 bar	0 ... 0.16 bar	-1 ... 0 bar

<sup>(1)</sup> Fluid temperature -20 ... 100 °C, ambient temperature -10 ... 50 °C, others on request

<sup>(2)</sup>  $\varnothing M$  according to dimension tables below

### Flange dimensions (mm) ANSI B16-5 / EN 1759-1

DN	Class	$\varnothing D$	$\varnothing K$	$\varnothing L$	N	EN1759-1		ANSI B16-5		$\varnothing d1$ <sup>(2)</sup>	$\varnothing M$ in mm <sup>(3)</sup>	Weight in kg
						C <sup>(1)</sup>	f1 <sup>(2)</sup>	C <sup>(1)</sup>	f1 <sup>(2)</sup>			
2"	150	152	120.6	19	4	22.2	1.6	22.5	2	91.9	54	2.4
	300	165	127	19	8	25.4	1.6	25.7	2	91.9	54	3.2
	600	165	127	19	8	35	6.4	35.74	7	91.9	54	4.2
	900/1500	216	165.1	25.4	8	47.7	6.4	48.1	7	91.9	54	10.1
	2500	235	171.5	28.5	8	60.4	6.4	60.9	7	91.9	54	15.6
2" 1/2	150	178	139.7	19	4	25.4	1.6	25.7	2	104.6	54	4
	300	190	149.2	22.2	8	28.6	1.6	28.9	2	104.6	54	4.9
	600	190	149.2	22.2	8	38.2	6.4	38.6	7	104.6	54	6.1
	900/1500	244	190.5	28.6	8	50.9	6.4	51.3	7	104.6	54	14
3"	150	190	152.4	19	4	27	1.6	27.3	2	127	89	5
	300	210	168.3	22.2	8	31.8	1.6	32	2	127	89	6.9
	600	210	168.3	22.2	8	41.4	6.4	41.8	7	127	89	8.5
	900	241	190.5	25.4	8	47.7	6.4	48.1	7	127	89	13.1

### Flange dimensions (mm) EN 1092-1







DN	PN	$\varnothing D$	$\varnothing K$	$\varnothing L$	N	EN1092		$\varnothing d1$ <sup>(2)</sup>	$\varnothing M$ in mm <sup>(3)</sup>	Weight in kg
						C <sup>(1)</sup>	f1 <sup>(2)</sup>			
50	10/16	165	125	18	4	19	3	102	54	2.9
	25/40	180	135	22	4	22.2	3	102	54	3.2
	63	195	145	26	4	31.8	3	102	54	4.6
	100	195	145	26	4	44.5	3	102	54	5.7
65	10/16	185	145	18	8	57.2	3	122	54	3.5
	25/40	185	145	18	8	22.2	3	122	54	4.3
	63	205	160	22	8	25.4	3	122	54	5.7
	100	220	170	26	8	35	3	122	54	7.5
80	10/16	200	160	18	8	47.7	3	138	89	4.6
	25/40	200	160	18	8	23.8	3	138	89	5.6
	63	215	170	22	8	28.6	3	138	89	6.9
	100	230	180	26	8	38.2	3	138	89	8.9

<sup>(1)</sup> Indicative Cmax for raised face. Dimension C could be different depending on material and type of face.

<sup>(2)</sup> For raised face, codes B, G and R.

<sup>(3)</sup> Active diameter.

### Ordering codes for flange faces

Face Type	Drawing	ANSI B16-5		EN 1759-1		EN 1092-1	
			Codes		Codes		Codes
Flat face		Flat face Ra = 3.2...6.3 µm	A	Type A Ra = 3.2...6.3 µm	A	Type A Ra = 3.2...6.3 µm	A
Raised face		Raised face (2) <sup>(1)</sup> Raised face (7) <sup>(2)</sup> Ra = 3.2...6.3 µm	G R	Type B (1.6) <sup>(1)</sup> Type B (6.4) <sup>(2)</sup> Ra = 3.2...6.3 µm	G R	Type B1 Ra = 3.2...12.5 µm	B
Male tongue		Male tongue large Male tongue small Ra = 0.8...3.2 µm	H I	Type CL Type CS Ra = 0.8...3.2 µm	H I	Type C Ra = 0.8...3.2 µm	C
Female groove		Female groove large Female groove small Ra = 0.8...3.2 µm	K L	Type DL Type DS Ra = 0.8...3.2 µm	K L	Type D Ra = 0.8...3.2 µm	D
Male Spigot		Male spigot large Male spigot small Ra = 3.2...6.3 µm	M N	Type E Ra = 3.2...6.3 µm	M	Type E Ra = 3.2...12.5 µm	E
Female Spigot		Female spigot large Female spigot small Ra = 3.2...6.3 µm	O P	Type FC Ra = 3.2...6.3 µm	O	Type F Ra = 3.2...12.5 µm	F
Ring joint face		Ring joint face Ra = 0.4...1.6 µm	Q	Type J Ra = 0.4...1.6 µm	Q	N/A	

<sup>(1)</sup> Class 150 and 300

<sup>(2)</sup> Class 600, 900, 1500, 2500

### Pre-selection guide for diaphragm seals with flange connection

Flange face	Codes	Stainless steel	Hastelloy B2	Hastelloy C276	Hastelloy C4	Tantalum	Monel 400	Uranus B6	Titanium
Flat face	A	D820	D820/D824	D820/D824	D820/D824	D824			
Raised face	B, G, R	D820/D821		D820/D821/D824					
Male tongue	C, H, I	D820	D820 D825	D820 D825	D820 D825	n/a	D825	D820 D825	D825
Female groove	D, K, L								
Male spigot	E, M, N								
Female spigot	F, O, P								
Ring joint face	Q								

Designation	Flush diaphragm	DN		Remark
		Min.	Max.	
D820	Yes	25	100	Only diaphragm in specific material, flange always stainless steel
D821	No	15	25	All wetted parts in specific materials
D824	Yes	50	100	All wetted parts in specific materials
D825	Yes	50	80	All wetted parts in specific materials

### Ordering details D825

Model		D825	-			.	2		.		
Flanged diaphragm seal with specific materials		D825	-								
<b>Mounting</b>											
Direct mounting			1								
St. steel capillary with St. steel protection			A								
St. steel capillary with St. steel protection and PVC sheath			B								
St. steel capillary with reinforced St. steel protection			C								
<b>For special capillary Ø 2.5 mm (seals mounted on MX, MZ, RP, RD)</b>											
St. steel capillary Ø 2.5 with St. steel protection			G								
St. steel capillary Ø 2.5 with St. steel protection and PVC sheath			H								
St. steel capillary Ø 2.5 with reinforced St. steel protection			J								
<b>Capillary length</b>											
Without (direct mounting)			0								
1.5 m			E								
3 m			3								
4.5 m			F								
6 m			6								
9 m			9								
12 m			D								
<b>Instrument connection</b>											
G1/2 female			L								
G1/4 female			H								
1/2 NPT female			N								
1/4 NPT female			8								
1/4 NPT male (only with capillary)			5								
1/2 NPT male (only with capillary)			6								
<b>Flange standard</b>											
ANSI B16-5			2								
EN 1092-1			4								
EN 1759-1			6								
<b>Material counter flange</b>											
Stainless steel 1.4404 (316L)			2								
<b>PN</b>											
<b>ANSI B16-5 / EN 1759-1</b>											
Class 150			1								
Class 300			2								
Class 600			3								
Class 900			4								
Class 1500			5								
Class 2500			6								
<b>EN 1092-1</b>											
PN10			C								
PN16			D								
PN25			F								
PN40			G								
PN63			N								
PN100			J								
<b>Diaphragm coating<sup>(1)</sup></b>											
0			Without								
1			PTFE 0.02 mm								
4			HALAR 0.2 mm								
<b>Diaphragm material and flange face</b>											
3			Uranus B6 (1.4539)								
5			Hastelloy B2 (2.4617)								
6			Hastelloy C276 (2.4819)								
A			Hastelloy C4 (2.4610)								
8			Titanium								
9			Monel 400								
<b>Flange face type</b>											
x			See table page 3 (codes)								
<b>DN</b>											
<b>ANSI B16-5 / EN 1759-1</b>											
7			2"								
8			2" 1/2								
9			3"								
<b>EN 1092-1</b>											
H			50								
J			65								
K			80								

<sup>(1)</sup> No coating for flange facing types with groove, codes H, I, K, L, O, P, Q, C, D, F