



### Main Features

- Pressure range from 160 mbar to 160 bar
- Temperature -60 °C ... 200 °C
- Class 150 to 900
- NPS 1/2" to 2"1/2
- PN10 to PN160
- DN10 to DN65

### Applications

- Oil & Gas / Chemical
- Water / Waste water
- Energy
- Process technic



### Technical Data

This diaphragm seals with flanged process connection are used to protect pressure gauges from high temperatures, aggressive or corrosive fluids.

The design of the process flange allows direct mounting on standardized flange connections of pipes or tanks.

Different diaphragm materials can be selected to adapt the seal to various applications and process fluids.

The diaphragm seals can be mounted to pressure gauges or pressure switches directly or with a flexible capillary. For use with electronic transmitters for pressure and differential pressure the product series D9xx is recommended, especially for low pressure ranges.

The filling fluid of the measuring system has to be chosen compatible to the application.

Min. pressure ranges	See table on page 2
Temperature	-60 °C ... +200 °C <sup>1)</sup>
Filling liquids	LRS1: -15 °C ... +150 °C LRS9: -40 °C ... +200 °C high temperature oil Other liquids on request
Mounting	Direct
Process flange	Stainless steel 1.4404 (AISI 316L) <sup>1)</sup>
Flange types	<b>ASME B16.5 / EN1759-1:</b> class 150 to 900, NPS 1/2" to 2"1/2 <b>EN1092-1:</b> PN 10 to 160, DN 10 to 65. Available flange faces see table on page 4. Other flange types on request.
Diaphragm	Stainless steel 1.4435 (AISI 316L) Option: Hastelloy, Uranus, Tantalum and Monel 400 (see ordering details on page 5)
Maximum pressure	According to the PN or the class of the flange and its standardized pressure temperature relation

<sup>1)</sup> For temperatures up to 400 °C please use the series D418 and D438

### Materials

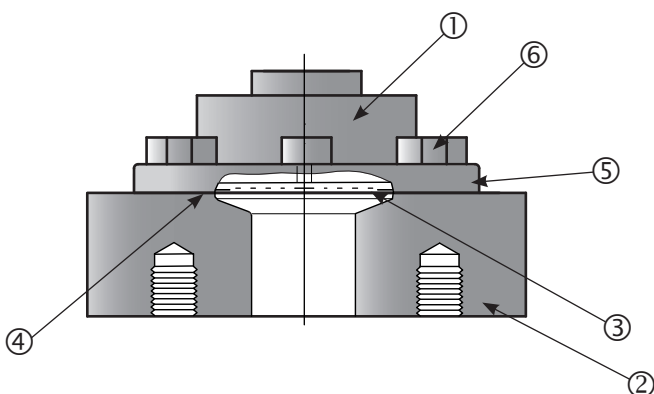

	N°	D415	D425	D435
Upper part	①	Stainless steel 1.4404		
Process flange	②	Stainless steel 1.4404 <sup>1)</sup>		
Diaphragm	③	Stainless steel 1.4435 <sup>1)</sup>		
Gasket	④	PTFE		
Fixing flange <sup>3)</sup>	⑤	Stainless steel 1.4301 <sup>2)</sup>	— <sup>4)</sup>	
Screws	⑥	Stainless steel 1.4301 <sup>2)</sup>		

<sup>1)</sup> Others materials see ordering details on page 5

<sup>2)</sup> 1.4404 (316L) with option 1999

<sup>3)</sup> Stamped parts for D415 and D425

<sup>4)</sup> The upper part of the D435 is a flange directly mounted on the process flange

### Dimensions (mm)

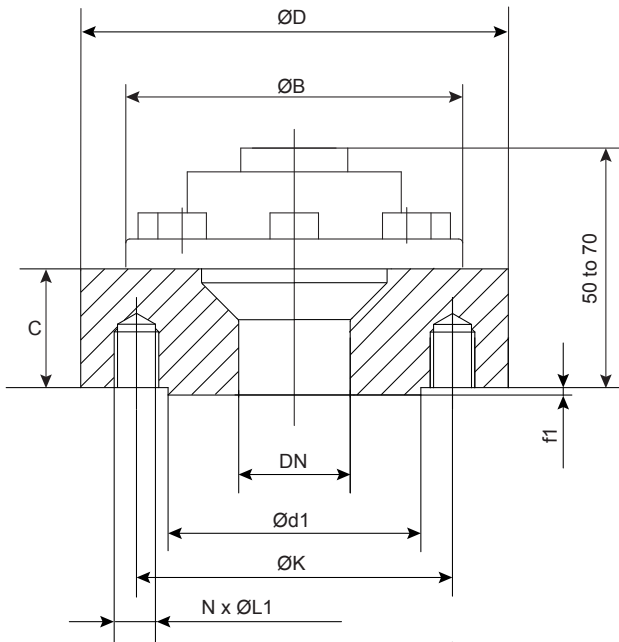

### Pressure limitations and dimensions of the upper part

Type	Min. pressure ranges <sup>1)</sup>		P <sub>max</sub> <sup>2)</sup>	Ø B
	Gauge	Compound		
D415	0 ... 10 bar	-1 ... 9 bar	160 bar	85
D425	0 ... 1 bar	-1 ... 3 bar	40 bar	85
D435	0 ... 0.16 bar	-1 ... 0 bar	25 bar	120

<sup>1)</sup> Fluid temperature -20 ... 100 °C, ambient temperature -10 ... 50 °C for pressure gauges DN100/150/160, others on request.

<sup>2)</sup> The maximum pressure is also limited by the process flange.

### Flange dimensions (mm) ANSI B16-5 / EN 1759-1

DN	Class	Ø D	C	Ø K	N	EN1759-1		ANSI B16-5		Ø d1 <sup>3)</sup>	Weight in kg <sup>1)</sup>		
						Ø L1	f1 <sup>3)</sup>	Ø L1	f1 <sup>3)</sup>		D415	D425	D435
1/2"	150	89	32/37 <sup>2)</sup>	60.3	4	M14	1.6	1/2 UNC	2	35.1	-	2.0	2.8
	300	95	32	66.7	4	M14	1.6	1/2 UNC	2	35.1	2.2	-	-
	600	95	37	66.7	4	M14	6.4	1/2 UNC	7	35.1	2.0	-	-
	900	121	44	82.6	4	M20	6.4	3/4 UNC	7	35.1	2.8	-	-
3/4"	150	99	32/35 <sup>2)</sup>	69.8	4	M14	1.6	1/2 UNC	2	42.9	-	2.3	3.0
	300	117	32	82.6	4	M16	1.6	5/8 UNC	2	42.9	2.4	-	-
	600	117	32	82.6	4	M16	6.4	5/8 UNC	7	42.9	2.7	-	-
	900	130	44	88.9	4	M20	6.4	3/4 UNC	7	42.9	3.2	-	-
1"	150	108	32/37 <sup>2)</sup>	79.4	4	M14	1.6	1/2 UNC	2	50.8	-	2.5	3.2
	300	124	32	88.9	4	M16	1.6	5/8 UNC	2	50.8	3.3	-	-
	600	124	37	88.9	4	M16	6.4	5/8 UNC	7	50.8	3.0	-	-
	900	149	44	101.6	4	M24	6.4	7/8 UNC	7	50.8	4.0	-	-
1"1/4	150	117	32/37 <sup>2)</sup>	88.9	4	M14	1.6	1/2 UNC	2	63.5	-	3.3	3.7
1"1/2	150	127	32/37 <sup>2)</sup>	98.4	4	M14	1.6	1/2 UNC	2	73.2	-	3.5	4.2
2"	150	152	48	120.6	4	M16	1.6	5/8 UNC	2	91.9	-	-	5.7
2"1/2	150	178	48	139.7	4	M16	1.6	5/8 UNC	2	104.6	-	-	5.8

<sup>1)</sup> Versions with "-" are not available.

<sup>2)</sup> D425/435

<sup>3)</sup> For raised faces, codes B, G, R

### Flange dimensions (mm) EN 1092-1







DN	PN	Ø D	Ø K	C	Ø L1	N	f1 <sup>3)</sup>	Ø d1 <sup>3)</sup>	Weight in kg <sup>1)</sup>		
									D415	D425	D435
10	10	90	60	32/36 <sup>2)</sup>	M12	4	2	40	–	2	2.8
	16	90	60	32/36 <sup>2)</sup>	M12	4	2	40	–	2	2.8
	25	90	60	32/36 <sup>2)</sup>	M12	4	2	40	–	2	2.8
	40	90	60	32	M12	4	2	40	–	2	–
15	10	95	65	32/36 <sup>2)</sup>	M12	4	2	45	–	2.2	3
	16	95	65	32/36 <sup>2)</sup>	M12	4	2	45	–	2.2	3
	25	95	65	32/36 <sup>2)</sup>	M12	4	2	45	–	2.2	3
	40	95	65	32	M12	4	2	45	–	2.2	–
	63	105	75	37	M12	4	2	45	2.5	–	–
	100	105	75	37	M12	4	2	45	2.5	–	–
	160	105	75	37	M12	4	2	45	2.5	–	–
20	10	105	75	32/38 <sup>2)</sup>	M12	4	2	58	–	2.4	3.2
	16	105	75	32/38 <sup>2)</sup>	M12	4	2	58	–	2.4	3.2
	25	105	75	32/38 <sup>2)</sup>	M12	4	2	58	–	2.4	3.2
	40	105	75	32	M12	4	2	58	–	2.4	–
	63	130	90	37	M12	4	2	58	3.6	–	–
	100	130	90	37	M16	4	2	58	3.6	–	–
25	10	115	85	32/38 <sup>2)</sup>	M12	4	2	68	–	2.7	3.6
	16	115	85	32/38 <sup>2)</sup>	M12	4	2	68	–	2.7	3.6
	25	115	85	32/38 <sup>2)</sup>	M12	4	2	68	–	2.7	3.6
	40	115	85	32	M12	4	2	68	–	2.7	–
	63	140	85	37	M16	4	2	68	4.2	–	–
	100	140	100	37	M16	4	2	68	4.2	–	–
	160	140	100	37	M16	4	2	68	4.2	–	–
32	10	140	100	35/36 <sup>2)</sup>	M16	4	2	78	–	4.1	4
	16	140	100	35/36 <sup>2)</sup>	M16	4	2	78	–	4.1	4
	25	140	100	35/36 <sup>2)</sup>	M16	4	2	78	–	4.1	4
	40	140	100	35	M16	4	2	78	–	4.1	–
40	10	150	110	35/36 <sup>2)</sup>	M16	4	3	88	–	4.7	5.8
	16	150	110	35/36 <sup>2)</sup>	M16	4	3	88	–	4.7	5.8
	25	150	110	35/36 <sup>2)</sup>	M16	4	3	88	–	4.7	5.8
	40	150	110	35	M16	4	3	88	–	4.7	–
50	10	165	125	36	M16	4	3	102	–	–	6.2
	16	165	125	36	M16	4	3	102	–	–	6.2
	25	185	135	36	M16	4	3	102	–	–	6.2
65	10	185	145	36	M16	8	3	122	–	–	7.3
	16	185	145	36	M16	8	3	122	–	–	7.3
	25	185	145	36	M16	8	3	122	–	–	7.3

<sup>1)</sup> Versions with "-" are not available.

<sup>2)</sup> D425/435

<sup>3)</sup> For raised faces, codes B, G, R

### Ordering codes for flange faces

Face Type	Drawing	ANSI B16-5		EN 1759-1		EN 1092-1	
			Codes		Codes		Codes
Flat face		Flat face Ra = 3.2...6.3 µm	A	Type A Ra = 3.2...6.3 µm	A	Type A Ra = 3.2...6.3 µm	A
Raised face		Raised face (2) <sup>(2)</sup> Raised face (7) <sup>(3)</sup> Ra = 3.2...6.3 µm	G R	Type B (1.6) <sup>(2)</sup> Type B (6.4) <sup>(3)</sup> Ra = 3.2...6.3 µm	G R	Type B1 Ra = 3.2...12.5 µm	B
Male tongue		Male tongue large <sup>(1)</sup> Male tongue small <sup>(1)</sup> Ra = 0.8...3.2 µm	H I	Type CL <sup>(1)</sup> Type CS <sup>(1)</sup> Ra = 0.8...3.2 µm	H I	Type C Ra = 0.8...3.2 µm	C
Female groove		Female groove large Female groove small Ra = 0.8...3.2 µm	K L	Type DL Type DS Ra = 0.8...3.2 µm	K L	Type D Ra = 0.8...3.2 µm	D
Male Spigot		Male spigot large Ra = 3.2...6.3 µm	M	Type E Ra = 3.2...6.3 µm	M	Type E Ra = 3.2...12.5 µm	E
Female Spigot		Female spigot large Ra = 3.2...6.3 µm	O	Type FC Ra = 3.2...6.3 µm	O	Type F Ra = 3.2...12.5 µm	F
Ring joint face		Ring joint face Ra = 0.4...1.6 µm	Q	Type J Ra = 0.4...1.6 µm	Q	N/A	

<sup>(1)</sup> Not applicable for 1"1/4 and 1"1/2

<sup>(2)</sup> Class 150 and 300

<sup>(3)</sup> Class 600 and 900

### Ordering details D400

	D4xx	-			.			.				
<b>Model</b>												
High pressure type	D415											
Medium pressure type	D425											
Low pressure type	D435											
<b>Upper part</b>												
St. steel 1.4404 (316L)		2										
<b>Instrument connection</b>												
G1/2 female			L									
G1/4 female			H									
1/2 NPT female			N									
1/4 NPT female			8									
<b>Diaphragm material</b>												
St. steel 316L (1.4435)				2								
Uranus B6 (1.4539)				3								
Hastelloy B2 (2.4617)				5								
Hastelloy C276 (2.4819)				6								
Tantalum				7								
Monel 400				9								
<b>Diaphragm coating <sup>2)</sup></b>												
Without					0							
PTFE 0.02 mm					1							
HALAR 0.2 mm					4							
Adhesive PTFE lining 0.25 mm <sup>3)</sup>					2							
Gold 15 µm					7							
<b>Process flange standard</b>												
ANSI B16-5					2							
EN 1092-1					4							
EN 1759-1					6							
<b>PN/Class</b>												
<b>ANSI B16-5 / EN 1759-1</b>												
Class 150					1							
Class 300					2							
Class 600					3							
Class 900					4							
<b>EN 1092-1</b>												
PN10					C							
PN16					D							
PN25					F							
PN40					G							
PN63					N							
PN100					J							
PN160					P							
<b>Process flange coating <sup>1)</sup></b>												
0										No coating		
1										PTFE 0.02 mm		
3										PTFE 2 mm <sup>4)</sup>		
4										HALAR 0.2 mm		
<b>Process flange material</b>												
1										Steel		
2										St. steel 1.4404 (316L)		
3										Uranus B6 (1.4539)		
5										Hastelloy B6 (2.4617)		
6										Hastelloy C276 (2.4819)		
9										Monel 400 (2.4360)		
<b>Flange face type</b>												
x										See table page 4 (codes)		
<b>DN</b>												
<b>ANSI B16-5 / EN 1759-1</b>												
2										1/2"		
3										3/4"		
4										1"		
5										1"1/4		
6										1"1/2		
7										2"		
8										2"1/2		
<b>EN 1092-1</b>												
A										10		
C										15		
D										20		
E										25		
F										32		
G										40		
H										50		
J										65		

<sup>1)</sup> No coating for flange facing types with groove, codes H, I, K, L, O, P, Q, C, D, F.

<sup>2)</sup> No diaphragm coatings on Tantalum diaphragms available.

<sup>3)</sup> Not for vacuum and compound pressure ranges.

<sup>4)</sup> Not for D415, max. 10 bar, max. 100°C, only flange face A, B, G and R, DN ≤ 40 (1"1/2).